

# Revelite AL - Backplate Mount (Square)

Installation Instructions

cerno®

## General Product information



This product is suitable for indoor dry and damp locations only.

THIS IS A LOW VOLTAGE (24VDC) FIXTURE AND MUST BE USED WITH THE SUPPLIED OR MANUFACTURER APPROVED POWER SUPPLY

This fixture can be controlled by a remote 0-10V low voltage dimmer. Please see page three for more information.

\*\*These instructions are for both the Low Profile and the Round fixture shapes. (Only the Low Profile fixture is shown throughout instructions)

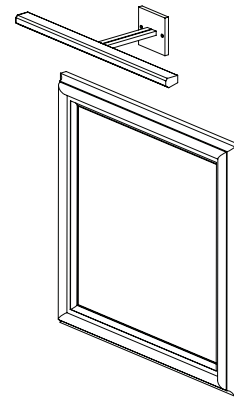

US Patent # 7,070,293 and 9,134,004.  
Other US and International Patents Pending



## CAUTION - RISK OF FIRE



This product requires installation by a qualified electrician. Before installing be sure to read all instructions and **TURN POWER OFF TO THE JUNCTION BOX**

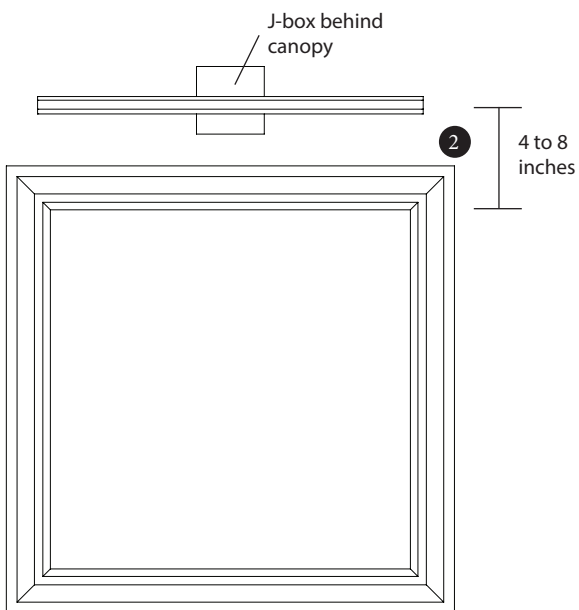

## Selecting and Installing a Junction Box

- 1 Determine where the center and top edge of the artwork will be located after installation. Place the centerpoint of the junction box vertically in line with the center of the artwork and 4 to 8 inches above the top edge of the artwork. This height is dependent upon on the height of the artwork's frame.
- 2 Determine where the center and top edge of the artwork will be located after installation. Place the centerpoint of the junction box vertically in line with the center of the artwork and 4 to 8 inches above the top edge of the artwork. This height is dependent upon on the height of the artwork's frame.
- 3 Feed an undimmed line voltage source to the J-box.

## Assemble the Fixture

- 4 Feed the four wires exiting the mounting arm through the center hole of the canopy. Orient the canopy so that the wire hole is above the screw mounting holes. Fasten the canopy to the mounting arm using the #8-32 button head screws and the 3/32" hex key included in the hardware kit. Tighten until connection is rigid and secure.

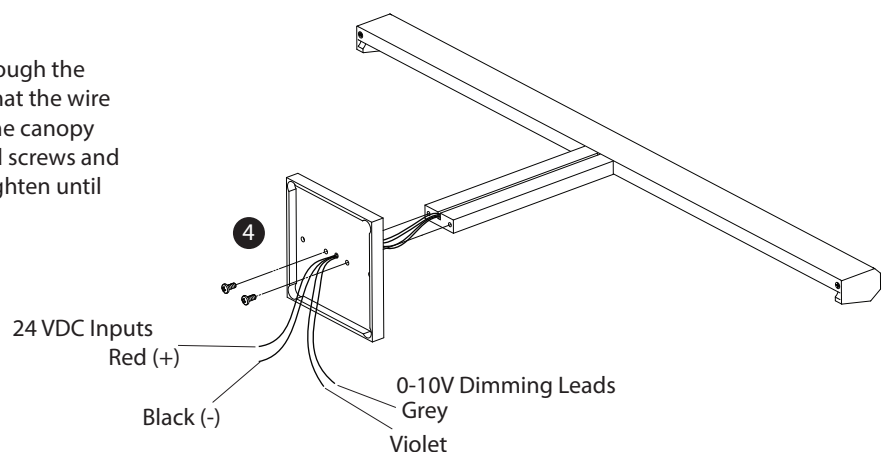

### Install the Power Supply and Crossbar

- 5 Make sure power to the J-box is turned off. Connect the line voltage leads to the input leads of power supply.
- 6 Place the power supply into the J-box.
- 7 Fasten the universal crossbar over the opening of the J-box using the included #8-32 x 3/4" Phillips head machine screws. Make sure the output wires from the power supply are accessible through the center opening of the universal crossbar.

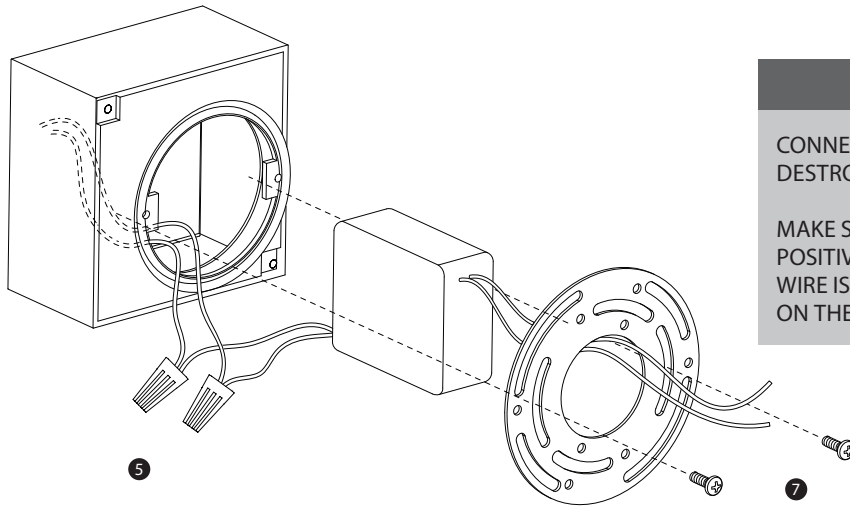

#### WARNING

CONNECTING THE FIXTURE DIRECTLY TO LINE VOLTAGE WILL DESTROY IT AND VOID THE WARRANTY!

MAKE SURE THAT THE RED WIRE IS CONNECTED TO THE POSITIVE (+) LEAD ON THE POWER SUPPLY, AND THE BLACK WIRE IS CONNECTED TO THE NEGATIVE (-) or GROUND LEAD ON THE POWER SUPPLY.

### Install the Fixture

- 8 Make wire connections between the output leads of the power supply and the input leads of the Revelite fixture.
- 9 If dimming control is desired, connect the violet and grey dimming leads to the 0-10V control leads (see more dimming information on page 3).
- 10 Fasten the Canopy to the Universal Crossbar using the included 8-32 Flathead Socket Screws and the 3/32" hex tool.

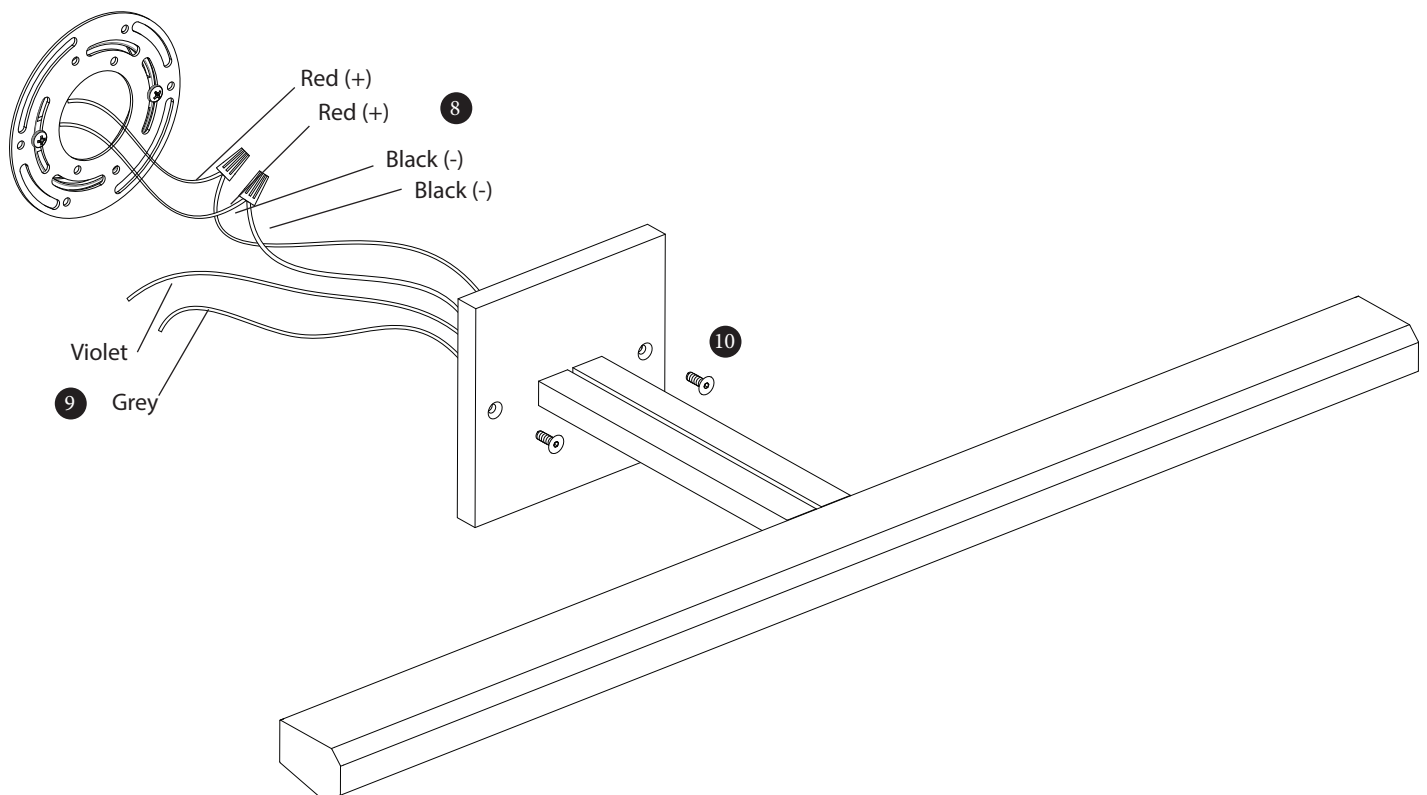

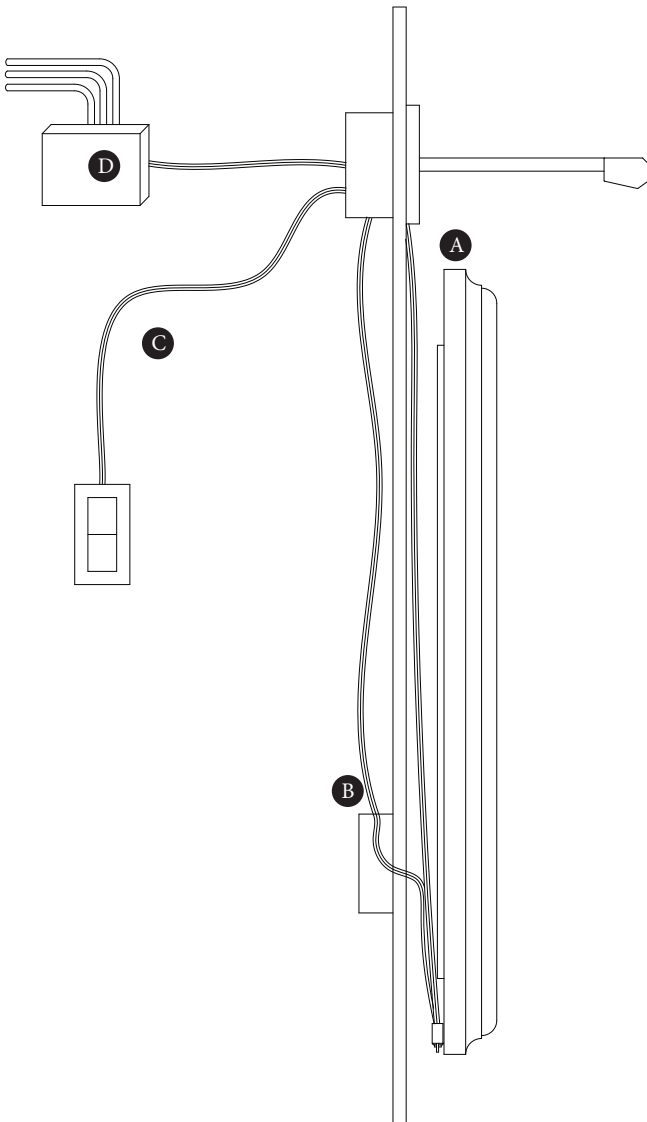

### Dimming Configurations

The Revelite AL can be dimmed only by using the violet and grey 0-10V leads that exit the fixture. Dimming control cannot be achieved using TRIAC, ELV, or other phase-dimming methods. The methods listed below for dimming the Revelite through the 0-10V leads are all recommended but are not entirely comprehensive; however, please use caution when experimenting with other methods of 0-10V control.

### Using the included Dimmer Switch

The Revelite AL can be dimmed only by using the violet and grey 0-10V leads that exit the fixture. Dimming control cannot be achieved using TRIAC, ELV, or other phase-dimming methods. The methods listed below for dimming the Revelite through the 0-10V leads are all recommended but are not entirely comprehensive; however, please use caution when experimenting with other methods of 0-10V control.

The leads necessary to make this connection can be configured in many different ways. Two of the most common are:

- A** If no additional modifications can be made other than installing a J-box, the low voltage wire can be made to exit on the underside of the canopy by etching a small recess in the drywall. This low voltage wire can then run the distance down the wall from the canopy to the dimmer switch, which should be mounted to the rear of the frame.
- B** If hiding all wires from view is necessary, the low voltage wire can be fed into the J-box that the fixture is mounted to and run inside the wall to a location behind the painting that is hidden from view. At this location a second smaller J-box can be installed to allow the wire to exit the wall, or a small hole will suffice. This control signal that passes through this wire is a Class 2 Low Voltage circuit; wire connections do not need to be housed in a metal enclosure.

### Using a Compatible 0-10V Wall Dimmer

- C** Many companies offer 0-10V compatible wall dimmers that preserve the same aesthetic as traditional wall dimmers. It is the installer's responsibility to ensure that the wall dimmer chosen is compatible and to follow the installation instructions included with that system correctly.

It is not possible to achieve dimming control through the use of a TRIAC, ELV, or phase-dimming wall dimmer.

### Using a Compatible Control System

- D** Many home and commercial lighting control systems are available that are compatible with 0-10V dimmable fixtures. Incorporating the Revelite AL fixture with older systems that were not originally compatible with 0-10V fixtures may be possible through the use of ten volt interfaces that can read a phase-dimmed input and produce a 0-10V output. Please inquire with the manufacturer of a control system before attempting to interface it with the Revelite AL fixture.

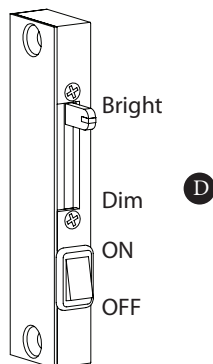

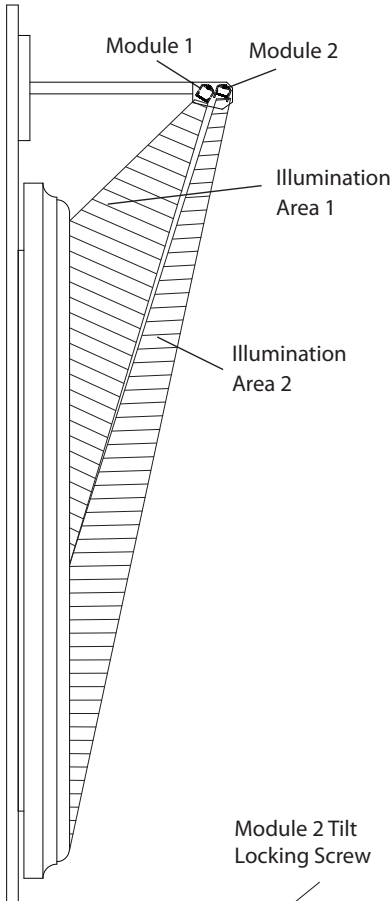

## Adjusting the Light Output

Every Revelite AL is custom tuned to illuminate the size of the canvas specified at the time of purchase. The following adjustments should not need to be made unless the fixture is moved to a different size canvas, or you would like to further tune the light output once it is mounted to the actual piece of art.

The Revelite AL consists of independently tilt-able and aim-able rows of LEDs, or “modules”. The Revelite AL1 has one module, and the Revelite AL2 has two. Module 1 is closest to the artwork and illuminates the upper area of the canvas, Module 2 is farther away from the artwork and illuminates the lower area of the canvas.

- 9 The brightness of each module is adjusted by turning the small phillips head screw located at the right side of the fixture when you are facing it. The screw should turn with very little resistance. Using too much force may damage delicate electronic components. Once the brightness has been adjusted for each module, the brightness balance between the two modules will stay the same when the fixture is dimmed using the included dimmer or a remote dimmer.
- 10 To tilt, or aim each module, loosen the locking screws at each end of the module, tilt the module to the desired position, and then tighten the locking screws.

A #1 phillips screwdriver and a 5/64" allen key have been included in the hardware lot.

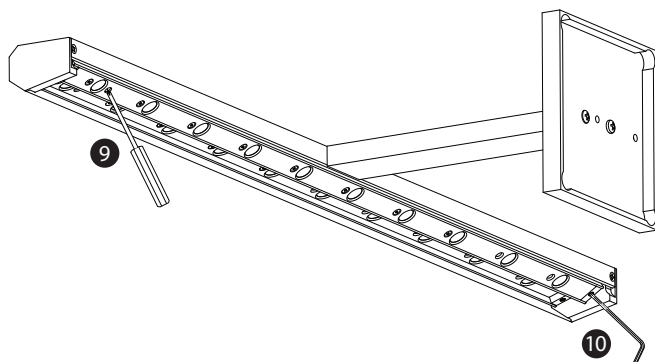
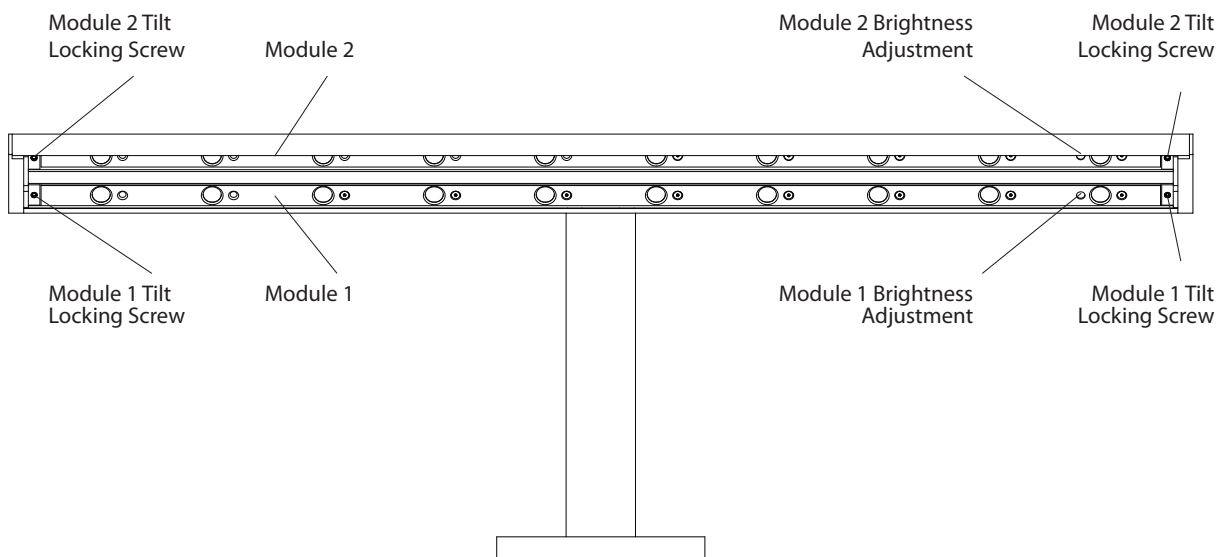

## Recommended Adjustment Procedure

The following procedure is recommended for adjusting your Revelite AL:

1. Turn the brightness of module 1 all the way down and the brightness of module 2 all the way up.
2. Adjust the tilt of module 2 until it covers the bottom two thirds of the canvas.
3. Turn the brightness up on module 1 and adjust the tilt until the top of the canvas is illuminated. Fine tune the brightness of module 1 until vertical uniformity is achieved.
4. Adjust the overall brightness using the dimmer switch.